



微信公众账号



FACEBOOK

安徽长庚光学科技有限公司

www.laowalens.com

服务热线:400-066-1316

Email: sales@laowalens.com

电话Tel: (+86) 551-69107990

地址: 合肥市庐阳区天水路与太和路交口庐阳中科大校友创新园5号楼

Add: Building 5, USTC Alumni Innovation Park, Crossing of Tianshui
and Taihe Road, Luyang District, Hefei City, Anhui Province, China

LAOWA FF S 15mm F4.5
W-Dreamer

使用手册

Instruction Manual

LAOWA 老蛙

本公司保留更改产品设计与规格的权利, 届时恕不另行通知;
本公司保留对此《使用说明》的最终解释权。

Please note we reserve the right to change our product's
design and specifications at any time without notice and
to the final interpretation of the *Instruction Manual*.



前言

真诚的感谢您选购FF S 15mm F4.5 W-Dreamer 镜头!为了让您充分理解本产品的使用方法和注意事项,请您在使用前仔细阅读本说明书。



 为了操作上的安全,使用本产品前请务必仔细阅读使用手册和注意事项,并将手册放在需要时容易取得的地方。如遇到不能解决的问题请拨打售后电话获取技术支持。

主要特色

- 该镜头是针对全画幅单反相机设计的超广角移轴镜头,非移轴情况下,最大视场角 110° ,在移轴情况下最大视场角可以达到 127.6° ,可覆盖 $\phi 65\text{mm}$ 像场直径。镜头采用特殊光学设计,保证光学素质的同时,镜头畸变控制接近“零”,是目前市场上难得的全画幅15mm焦距移轴镜头,更大的拓展了使用场景,增加了摄影师对于商业建筑摄影,镜头方面的选择。
- 移动量 $\pm 11\text{mm}$
在拍摄建筑的过程中,很多时候由于环境的限制,拍摄机位离建筑较近,若使用其他镜头甚至不能拍摄建筑全貌。此时,15mm的视角更能轻松的在有效空间内完成拍摄任务。借助 $\pm 11\text{mm}$ 的镜头偏移,让建筑物不会因为拍摄距离近、俯仰角度大或镜头焦距广而产生的近大远小的透视变化,让拍摄变得更为严谨。

主要特色

- 镜头结构
此镜头的机械机构全部采用金属部件,确保了镜头的组装精度和耐用性,镜头具备 $\pm 11\text{mm}$ 移轴机构,同时具有 360° 旋转机构,每 15° 一个旋转档位,方便摄影师在不同场景下拍摄。
镜头光学结构11组17片,采用了2片非球面镜片和3片ED镜片,保证镜头锐度,又最大限度的降低了色散和畸变,同时提高了边缘画质。
- 镜头支架、方镜支架
专业配套支架,为建筑接片提供方便。(选购件)
利用偏移功能,得到了相当于相机水平移动的效果,将在不同偏移位置分别拍摄的两张照片在画面中央附近合并成了全景照片。因为使用了移轴镜头的偏移,镜头入瞳点没有改变,因此并未产生透视感且合并处也几乎看不出来。
专为镜头设计的磁吸方镜支架(选购件)
可搭配使用100mm、150mm方形滤镜,在不同拍摄环境下,完成拍摄需求。

△ 安全注意事项

- 切勿自行拆解、修改或改装。当产品由于外力原因破损，切勿触碰外露部分或破损边缘处。
- 切勿放置于直射阳光下、封闭车辆中或其余高温处，否则过高的温度会使镜片和其他部件产生伸缩变形。
- 不使用镜头时，请将镜头前盖盖上或置于没有阳光照射处。凸透镜反射出的光线可能会聚集在附近物体上，导致发生火灾。
- 在逆光拍摄时，切勿将太阳置于画面中心，应该使太阳充分偏离画角，否则阳光会在相机内部聚集并导致火灾或灼伤眼睛。

■ 长期使用保养注意事项

- 避免触摸镜头表面，应用专用镜头布或气吹去除镜头表面的尘埃，不使用镜头时，应将镜头盖盖上。
- 使用镜头纸或镜头布清洁时，以螺旋的方式从中间向外擦拭镜头上的污垢以及指印。
- 镜头从寒冷的环境突然转移至温暖的环境时，镜头的外部以及内部镜片将会凝结水雾，所以在转移时应采取防潮保护措施。

各部件名称

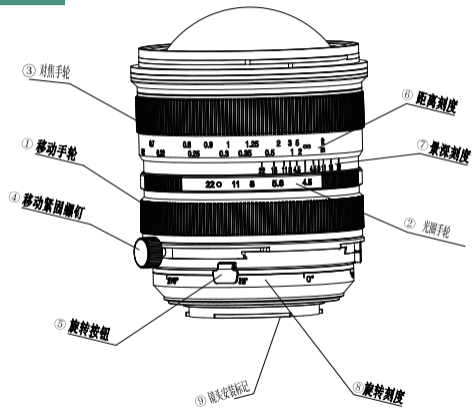

各部件名称

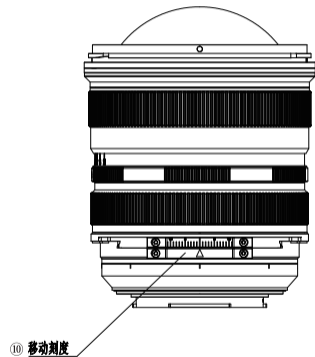

■ 镜头安装

取下镜头后盖。将镜头卡口上的安装标记⑨对准相机座圈上的对应标记，随后将镜头插入机身座圈，根据所购买卡口的安装方向旋转镜头，直至咔嚓声锁紧镜头。安装时请不要用力过猛，以免导致卡口损伤。

■ 镜头拆卸

关机后按住相机上的镜头释放按钮，依照所购买卡口的安装方向反向旋转镜头，随后将镜头从座圈中拔出。

装上镜头后，请尝试旋转镜头确认是否已将其固定在相机上。

■ 对焦方式

此款镜头是全手动对焦镜头，合焦时，缓慢旋转对焦环③，直至合焦。

不要过猛过快地旋转对焦环，避免用力过度损坏对焦环部件。

镜头上的距离刻度⑥与景深刻度⑦是出于指导目的。实际焦点与最深可能同刻度标记稍有不同。

■ 移动功能

移动功能的使用使得镜头的光轴平行得从影像平面的中心移开。

如果您用常规的镜头拍摄比如建筑，建筑物会因为透视逐渐变小。但是如果您使相机与建筑物平行并移动镜头，您可以纠正这个透视关系。当您拍摄一个反光的景物时，您可以移动相机使它不在镜头内，然后用移动功能拍摄拍照，这使得您不改变拍摄构图就可以使相机不在反光面出现。

■ 使用移动功能

- 1, 拧松④移动锁止机构
- 2, 转动①移轴环来调整移动量
- 3, 在达到移轴需求量时，拧紧锁止机构

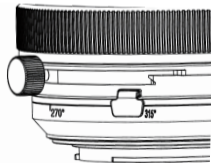

■ 转动功能

转动功能使您能通过转动移动装置来改变移动的方向。当镜头装在相机上时, 按住⑤转动锁定释放按钮, 然后转动。
转动装置可以转动 $\pm 180^\circ$ 。镜头在每 15° 位置设置限位。

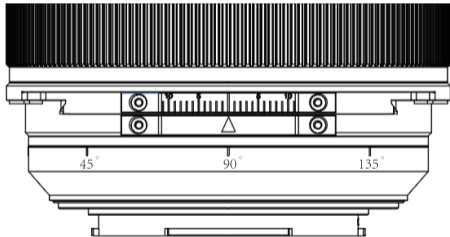

■ 光圈使用

光圈在镜头上调节, 根据拍摄环境和与所需要的景深, 转动光圈环② 来选择对应的光圈。

由于此镜头无CPU数据, 所以暂时无法记录光圈参数。

由于光圈为手动调节, 无法较好的使用快门优先模式, 但可以使用光圈优先模式(测光准确度视相机型号而定)。

FF S 15mm F4.5 W-Dreamer	
镜头型号	LAOWA FF S 15mm F4.5 W-Dreamer
画幅	全画幅
焦距	15mm
视角范围	127.6°
最大光圈	4.5
最小光圈	22
镜片结构	11组17片
光阑叶片	5片
最近摄影距离(物像距离)	20cm
合焦驱动方式	手动
镜头尺寸(直径/长)	φ79mm/103mm
重量	600g
卡口	佳能EF、RF、尼康F、Z, 索尼FE

新创意·新乐趣



Preface

Thank you very much for purchasing FF S 15mm F4.5 W-Dreamer Lens. Read this operation manual carefully to familiarize yourself with its contents and ensure that you can operate the product properly.



 *Keep the Instruction Manual in a safe place where it can easily be referenced whenever required. If you are still unable to solve the problem by reading the manual, please contact our after-sales service for further technical support.*

Features

- This lens is an ultra-wide-angle shift lens designed for full-frame SLR cameras. When you apply the shift function, the maximum angle of view can reach 127.6°, covering Φ 65mm image circle. The maximum angle of view is 110° without shift. The lens features special optical design, delivering excellent edge-to-edge sharpness and almost zero distortion. This 15mm full frame shift lens offers more professional architecture photography.
- The maximum shift amount of ± 11 mm.
It would be difficult to capture the whole building in a short distance with a typical lens. The ultra-wide 15mm field of view allows you to capture it with ease. And the ± 11 mm shift function also corrects any perspective distortion caused by large pitch angle or wide focal length.

Features

- Lens structure
The all-metal structure ensures the lens' assembly accuracy and reliability. The ± 11 mm shifting function with 360° rotation with clicks stops for each 15° step on the shift mechanisms gives you lots of flexibility. The lens is constructed by 17 optical elements in 11 groups with 2 aspherical lenses and 3 ED lenses to deliver edge-to-edge sharpness, excellent chromatic dispersion control and, distortion control.
- Lens holder, square filter holder
Professional lens support can use for easier photos stitching (Sold Separately). Utilizing the shift mechanism, users can create panoramas by stitching two image shots with different shifted positions together. There would be no converging lines in the picture since the entrance pupil didn't move.
Magnetic filter holder that specially designed for this lens works with 100mm and 150mm square filters (Sold Separately).

Precautions

△ Safety Precautions

- Do not disassemble, modify the lens by yourself. Do not touch the internal parts that become exposed as the result of external force.
- Do not leave the lens where it will be exposed to high temperatures, such as in direct sunlight and an enclosed vehicle. Excessive heat may deform the glass elements and other parts of the lens.
- Whether it is attached to the camera or not, do not leave the lens under the sun without the lens cap attached. This is to prevent the lens from concentrating the sun's rays, which could cause a fire.
- Do not place the sun in the frame center when shooting with backlight. Doing so might cause a fire or harm your eyes.

Precautions

■ Maintenance Precautions

- Do not touch the surface of the lens directly. Brush off any dust with a blower. Wipe the surface with a cleaning cloth or a lens tissue.
- Try a circular motion from the center outward to remove oil, fingerprints and grime on the lens surface.
- If your lens is brought directly from a cold place to a warm place, condensation may appear on the lens. To avoid this, be sure to take some action to protect the lens.

Nomenclature

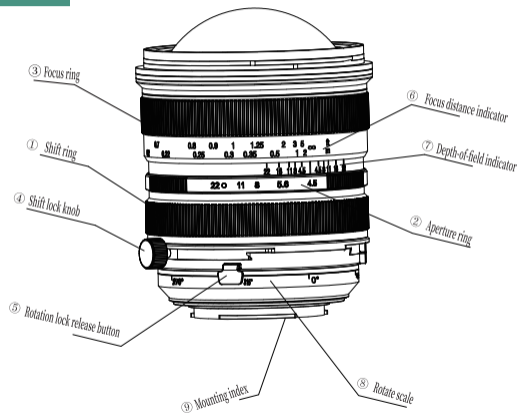

Nomenclature

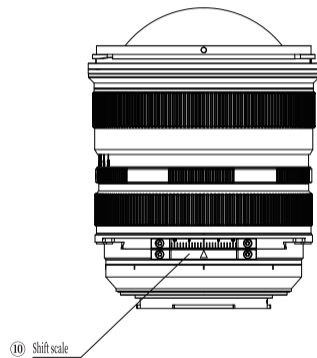

■ To attach the Lens

Remove the rear lens cap. Align the mounting index^⑨ on the lens bayonet with the mounting index on the camera, and place the lens on the camera mount, then rotate the lens according to the proper direction of the mount type until it locks. Do not use excessive force during installation to avoid damage to the bayonet.

■ To remove the lens

Turn the camera off. While pressing and holding the lens release button on the camera, rotate the lens in the reverse direction for attaching the lens until it stops, then detach the lens.

■ Focusing

This is a fully manual lens. Rotate the focusing ring^③ slowly to get focus. Turn the focus ring slowly and gently to prevent the focus mechanism from damage. The distance scale^⑥ and depth of field scale^⑦ are for instructional purposes. Actual focus and DOF may slightly differ from those scale indications.

■ Shift

The top of the building tapers away when you photograph a subject such as a building with a normal lens. But by placing the camera parallel to the building and shifting the lens, you can correct this tapering effect.

When shooting a subject with a reflective surface, you can move the camera to a position where the camera does not appear in the shot. Then you can keep the camera out of the frame without having to change the composition by shifting the lens.

■ Using shift

1. Loosen the shift lock knob^④
2. Turn the shift ring^① to adjust the amount of shift.
3. Turn the shift lock knob to lock the amount of shift for the shot.

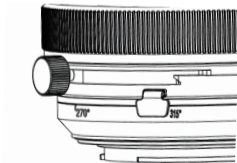

■ Rotation

The rotation function enables you to change the direction of shift by rotating the shift mechanism.

With the lens mounted on the camera, push the rotation lock release button⑤ and then turn the shift mechanism.

The mechanism can be rotated through $\pm 180^\circ$. The lens clicks every 15° .

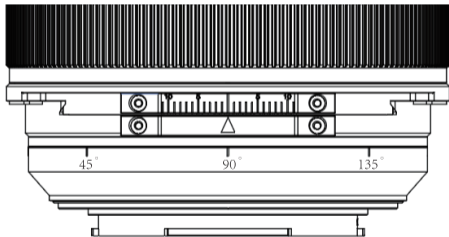

■ Setting the Aperture

Aperture is set through the aperture ring on the lens. According to the shooting situation and desired depth of field, rotate the aperture ring② on the lens to the corresponding aperture.

Since the lens has no CPU data, the aperture value can't be recorded.

Aperture-priority is a better option than Shutter-priority for the lens because of its manual aperture. (Note that metering precision depends on the camera models.)

Specifications

FF S 15mm F4.5 W-Dreamer	
Format	Full Frame
Focal Distance	15mm
Maximum Angle of View	127.6°
Maximum Image Circle Diameter	Φ65mm
Max. Aperture	4.5
Min. Aperture	22
Lens Structure	17 elements/ 11 groups
Aperture Blades	5
Min. Shooting Distance	20cm
Focusing	MF
Dimensions	Φ79mm/103mm
Weight	600g
Mounts	Canon EF, RF/Nikon F,Z/Sony FE

New Idea . New Fun .